

# PATTON & COOKE ACCESSORIES

## SHOVEL CABLE LIFT

### SHOVEL CABLE LIFT

A safe, innovative approach to relocating trailing cables using a shovel instead of multiple personnel. The Shovel Cable Lift reduces the amount of time spent moving cable, thus reducing shovel operation down time.

### FEATURES

- 5,000lb load capacity
- Integrated mounting brackets to safely secure cable to cable lift
- Innovative design to hold and relocate cable without causing damage which would cause expensive shovel operation delays
- Manufactured with long lasting, durable materials
- Fast & safe way to move cable in pit without the use of multiple personnel, thus saving time

CATALOGUE NUMBER: SCL-10

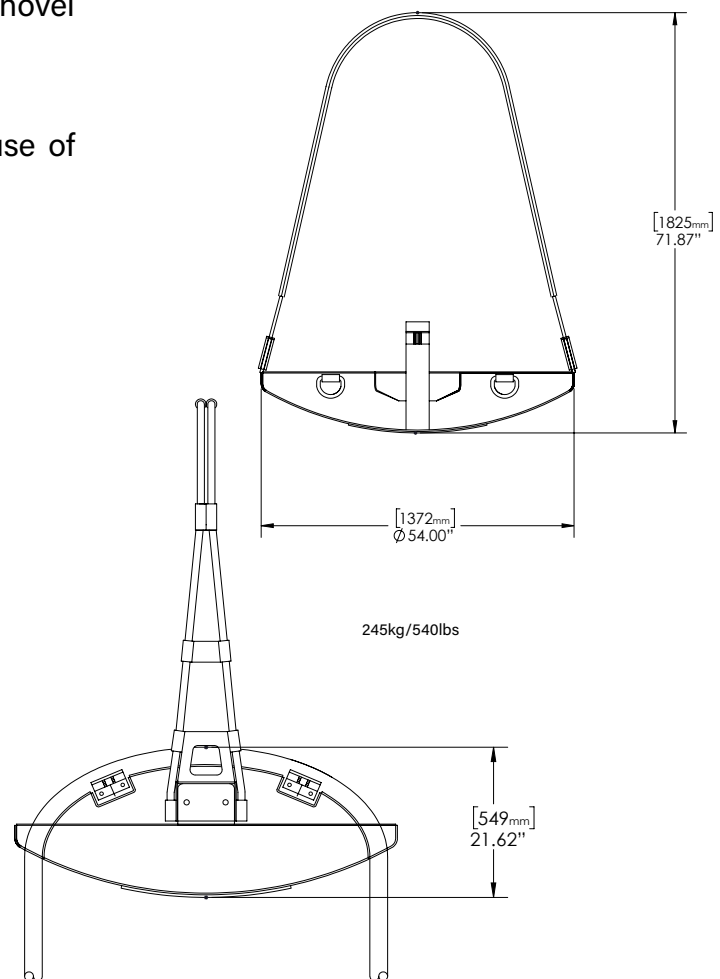

**PATTON & COOKE CO.**  
High Voltage Equipment Solutions. Design and Manufacturing.

#100 - 7795 128th Street  
Surrey, BC • V3W 4E6 • Canada  
Email: [info@pattonandcooke.com](mailto:info@pattonandcooke.com)  
[www.pattonandcooke.com](http://www.pattonandcooke.com)